

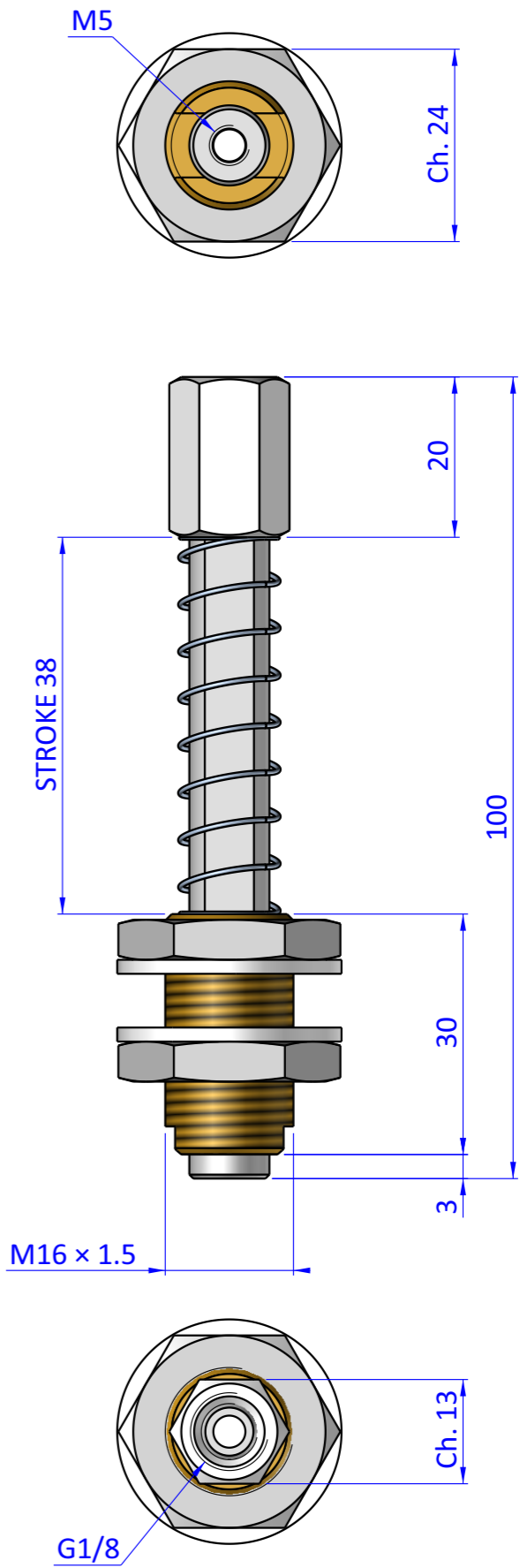

THE PROPERTY OF THE DRAWING IS ESTABLISHED BY LAW. IT IS FORBIDDEN TO PRODUCE OR SHOW IT TO THIRD PART - WITHOUT A WRITTEN AGREEMENT.

Item	Name	Q.ty
1	05.01.001.01	1
2	05.01.001.05	1
3	05.01.005.04	1
4	05.01.007.06	2
5	M.12x50	1
6	R.16.SCH	2

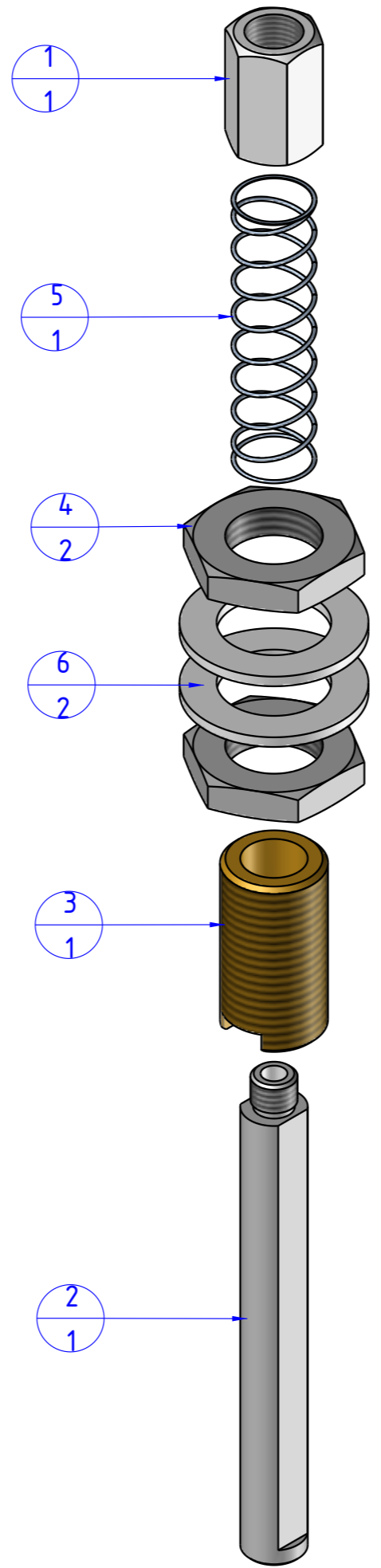

Format A3
UNI 936-76

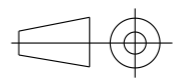
 FPS FPSERVICES AUTOMATION			DESIGNED FROM FPS Automation	REVIEW A
GENERAL TOLERANCE UNI - ISO 2768 CLASSE f	DESCRIPTION CA.05.01.011		DATE -	WEIGHT 0,096kg
			CODE CA.05.01.011	